

BOILING PAN TYPE M5 MINI

DESIGN

400mm tipping height.

Technical construction according to EN 13886.

The boiling pan is in stainless construction with fully welded pot in acid-proof stainless steel.

Hygienic design with a minimum of components on the outside of the boiling pan.

Well-insulated pot for good stability, low external temperature and high energy-efficiency.

The pressure vessel is constructed in such a way that the heat element is located under the water regardless of which position the vessel is in. It is not possible for it to boil dry.

Automatic water filling of the pot's steam jacket.

Wide, substantial lip on the pot minimises waste and ensures that the strainer plate does not buckle.

All equipment that is required to operate the boiling pan and stirrer is located in the pot's right support.

Very simple access for servicing via the boiling pan's support with only one lock per service hatch.

Main switch for electrical connection integrated in the boiling pan's right support.

Water connection equipped with shut-off valve as well as reverse siphon protection type EB according to EN 1717.

The boiling pan can be adapted in the factory for electricity and water connection from wall/ installation duct or from ceiling.

Low leakage filter for stirrer as standard enables connection to residual current circuit breaker for personal protection.

Electrical connection only for Cu cable. If Al cable is used, an adapter is required.

Enclosure class IPX5.



LID

Hinged, spring-balanced lid in plastic with integrated inspection grating. The material's insulating properties produce over 20% lower external temperature than a lid in stainless metal with normal operating and ambient temperatures, and thus also reduce the boiling pan's energy consumption.

Lid in insulating plastic entails a substantially lower risk of burn injuries and an energy saving compared with a stainless metal lid.

Plastic lid for a good work environment with more than 20dB (A) lower noise level than a lid in stainless metal. The noise level for a plastic lid is below the Swedish Work Environment Authority's limit values, in distinction from a lid in stainless metal.

The lid can be turned around its shaft, which provides an ergonomic work posture and a minimum of waste/splashes when cleaning.

CONTROL, GENERAL INFORMATION

Electronic control with graphic touch screen which provides a clear overview and simple operation.

Extra control panel with buttons which enable simultaneous use of tipping and water filling regardless of which menu is displayed on the touch screen.

Correct ergonomic position of control panel.

Integrated web server. Access from web browser via the local network.

All settings can be performed via the local network when necessary.

BOILING

Electronically controlled boiling function with double power stages and advanced temperature measurement with very high precision.

The boiling function can be programmed for automatic activation of heat-retention function according to set time, as well as for delayed start at a certain time.

93-95% efficiency, depending on pot size measured according to EFCEM standard.

Energy measurement via e-log. Energy consumption is calculated locally in the boiling pan's electronics and can be displayed on the touch screen.

WATER FILLING, POT

Fully automatic water filling with flow measurement in decilitre resolution.

Water pipe located on the pot, underneath the lid for optimum hygiene.

Manually controlled water filling possible at any time via a button on the control panel.

OPTIONS

Container cradle for simple and ergonomic emptying of the pot into containers. The cradle rotates together with the pot in the tipping motion, both during tipping and return, which keeps the number of heavy lifts to a minimum. The cradle can also be rotated half a turn and locked in a position to function as a surface on which to place items in direct connection to the pot.

Pistol hose including single lever mixer for hot and cold water. Option of adjusting the jet's concentration and pressure. Hanging device for pistol hose on the boiling pan's right support.

Strainer plate for, for example, emptying potato water. Wide and in robust construction with ergonomic handles.

Draining plate to facilitate emptying in smaller vessels. The draining plates create a concentrated jet when emptying fluid products. Wide and in robust construction with ergonomic handles.

Measuring rod for simple check of the amount in the pot.

Implement trolley. Practical for storage and transport of for example, strainer plates, Constructed entirely in stainless steel and available in models for two or four sets of tools.

Embedment fixture for optimal installation of boiling pans. Delivered pre-assembled for single, pair, triple rack etc. to minimise the risk of problems at the construction site. For optimal installation in the shortest time.

e-log for logging energy consumption throughout the boiling pan's service life. Data is saved locally in the boiling pan's electronics, and can be monitored from a standard web browser via the local network. Produce statistics of energy consumption, for example, per day, week or month in order to simply and pedagogically obtain feedback on the effect of energy saving measures in connection with use of the boiling pan.

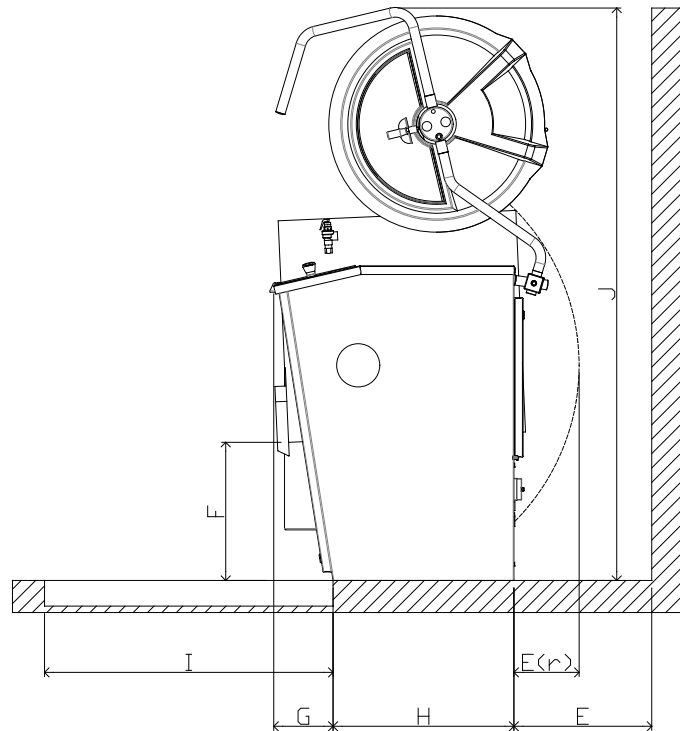
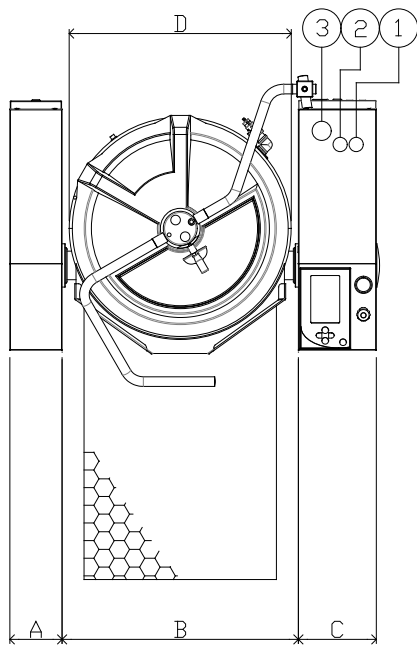
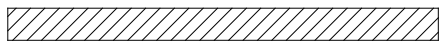
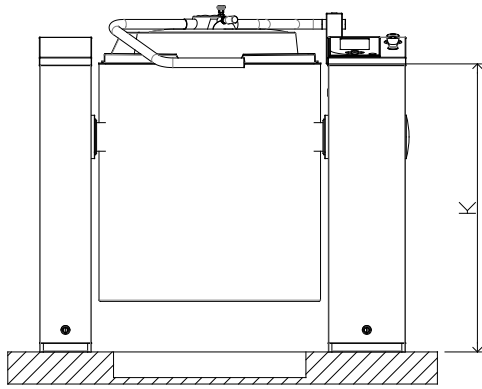

SPECIFICATIONS

TILTING KETTLE M5

TIPPING HEIGHT 400 MM

1. COLD WATER, THREAD R15 EXT.
 PRESSURE (MIN/MAX) 3bar/6bar
 HARDNESS (MIN/MAX) 3dH/10dH
 REC. FLOW 25L/MIN

2. HOT WATER, THREAD R15 EXT.
 PRESSURE (MIN/MAX) 3bar/6bar
 HARDNESS (MIN/MAX) 3dH/10dH
 REC. FLOW 11L/MIN
 TEMPERATURE (MAX) 65°C

3. ELECTRICAL CONNECTION, 3N 50HZ 400/230V. PE (BUILT-IN ISOLATION SWITCH)

Volume	A	B	C	D	E(r)	E	F	G	H	I	J	K	Output	Fuse	Heating time
Litres	mm	mm	mm	mm	mm	mm	mm	mm	mm	mm	mm	mm	kW	A	Approx. min
50	160	655	240	605	63	330	410	185	564	800	1716	900	15,0	25	25
75	160	655	240	605	152	330	410	185	564	800	1716	900	15,0	25	35
100	160	740	240	690	206	430	410	185	564	900	1786	900	22,5	35	30
150	160	960	240	910	369	430	410	185	564	900	1966	900	30,0	45	35
200	160	960	240	910	369	430	410	185	564	900	1966	900	35,0	63	35
300	160	1085	240	1035	503	530	410	185	564	900	2070	900	45,0	80	35
400	160	1085	240	1035	603	630	560	185	564	900	2220	1050	50,0	80	35